

VULCAN

V-Series™

Q2500

In an industry that constantly expects more from its equipment, the Vulcan V-Series™ delivers. With powerful engineering and advanced metallurgy, these fluid ends offer stronger uptime numbers and best-in-class reliability, longevity and field serviceability—all with fewer parts and easier installs.

Complete Cross Compatibility

Our simplified design means that all components are compatible across the V-Series™ suite.

/ V-Series™ T2250

/ V-Series™ Q2700

/ V-Series™ Q2500

/ V-Series™ Q3000

/ V-Series™ Q2500 — 60"

/ V-Series™ T3000

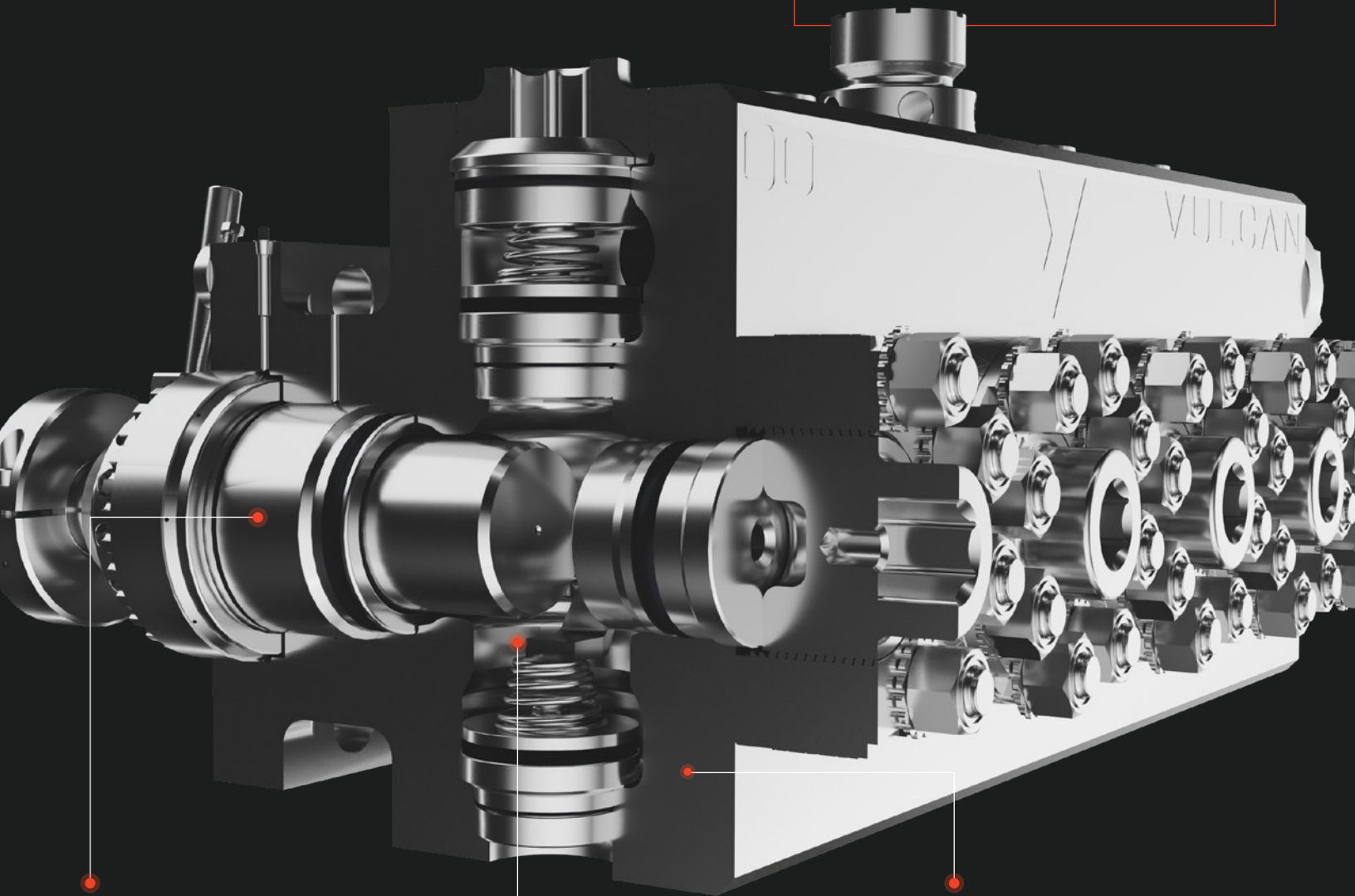

Field Replaceable Packing Sleeve

- Simplified and optional
- No need to remove from unit to replace
- Does not require electric or air compressed tools

Machine Finished Cross Bores

No hand blending for a more consistent quality and precision

Advanced Stainless™ Steel

Higher abrasion resistance than the industry standard 17-4/15-5PH materials, allowing for longer life on valve tapers and sealing areas



50%

fewer components per fluid end assembly

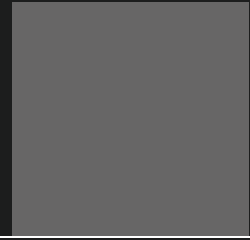

271 vs. 599

parts per V-Series™ assembly

parts per competitor assembly

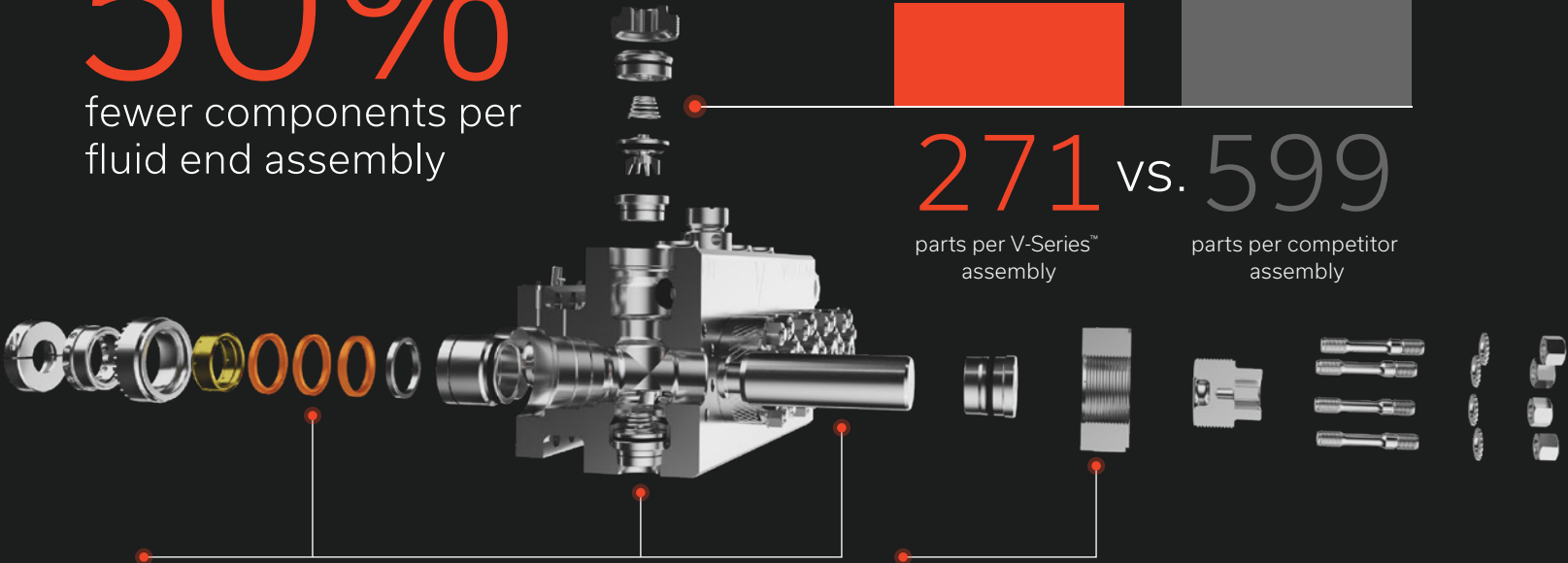

No Special High Change-Out Parts Needed

The V-Series™ can bolt up to anyone's fleet and continue using their current valves and seats, packing and plungers.

Modular Suction Cover Retainer System with 2" Hex

- Includes full maintenance with system install
- Eliminates seized and damaged fluid end threads
- Ends retainer nut cracking

Advanced Stainless™ Steel

Percentage Performance Increase vs. Competitors

